

FLOATING OFFSHORE WIND
CENTRE OF EXCELLENCE

Delivered by
CATAPULT
Offshore Renewable Energy

DYNAMIC CABLES AND ANCILLARY SYSTEMS – MARKET PROJECTIONS

FLOATING OFFSHORE WIND CENTRE OF EXCELLENCE



AUTHOR // Ellen Jump

DATE // 12-09-2021

DISCLAIMER

Whilst the information contained in this report has been prepared and collated in good faith, ORE Catapult makes no representation or warranty (express or implied) as to the accuracy or completeness of the information contained herein nor shall we be liable for any loss or damage resultant from reliance on same.

PREFACE – FLOATING OFFSHORE WIND CENTRE OF EXCELLENCE

Offshore Renewable Energy Catapult (ORE Catapult) has established the Floating Offshore Wind Centre of Excellence (FOW CoE). The FOW CoE is a collaborative programme with industry, academic and stakeholder partners.

The Vision of the FOW CoE is to establish an internationally recognised centre of excellence in floating offshore wind which will work towards reducing the Levelised Cost of Energy (LCOE) from floating wind to a commercially manageable rate, cut back development time for FOW farms and develop opportunities for the local supply chain, driving innovation in manufacturing, installation and Operations and Maintenance (O&M) methodologies in floating wind.

More details on the FOW CoE can be found on <https://ore.catapult.org.uk/what-we-do/innovation/fowcoe/>.



CONTENTS

1	INTRODUCTION	8
1.1	Report Scope	8
2	FLOATING OFFSHORE WIND DEPLOYMENT	9
2.1	UK	9
2.2	Rest of the World	10
3	DYNAMIC CABLE SYSTEMS FOR UK FLOATING WIND	12
3.1	Dynamic Cable Systems Overview	12
3.2	UK Project Configurations	13
3.3	System Configuration	14
3.4	Assumptions	18
3.5	Wind Farm Deployment Baseline Scenario	22
3.6	Local Content	23
4	UK MARKET REQUIREMENTS	24
4.1	Required Components	24
4.2	Required Services	34
5	UK MARKET REQUIREMENTS SENSITIVITY ANALYSIS	36
5.1	FOW Deployment Variation	36
5.2	Cable Material	39
5.3	Use of Static Cables	40
5.4	Introduction of TLPs	41
5.5	Floating Offshore Substations	41
5.6	Wind Farm Layout and Substation Size	41
6	GLOBAL MARKET REQUIREMENTS	42
7	SUMMARY	43
	APPENDIX 1 CABLE MATERIAL ALTERNATIVE DEPLOYMENT SCENARIO	44
	APPENDIX 2 STATIC CABLE ALTERNATIVE DEPLOYMENT SCENARIO	45

LIST OF FIGURES

Figure 1	Cumulative Floating Offshore Wind Deployment in the UK between 2020-2050	9
Figure 2	Global Cumulative FOW Deployment	10
Figure 3	Cumulative FOW Deployment by High Potential Export Country between 2020-2050	10
Figure 4	Cumulative FOW Deployment by Low Potential Export Country between 2020-2050	11
Figure 5	FOW Dynamic Cable System	12
Figure 6	Dynamic Cable System Taxonomy	13
Figure 7	Tapered Radial String (Courtesy of Peritus International)	15
Figure 8	FOW turbine and lazy wave cable configuration (Courtesy: Peritus International)	15
Figure 9	Dynamic Cable (Courtesy: JDR Cable Systems)	25
Figure 10	Cable hang-off clamp (Courtesy: Tekmar)	26
Figure 11	Pull-in head (Courtesy: Oceaneering)	27
Figure 12	Cable J-tube (Courtesy: Optimus Aberdeen)	27
Figure 13	Bend Stiffener (Courtesy: Kaylan Offshore)	29
Figure 14	Abrasion Protection (Courtesy: Balmoral Offshore)	30
Figure 15	Buoyancy module cross section (Courtesy: Balmoral Offshore)	31
Figure 16	Ballast Modules (Courtesy: Subsea Energy Solutions)	31
Figure 17	Wet Mate Connector (11kV) (Source: MacArtney)	32

LIST OF TABLES

Table 1	FOW Deployment to 2050 in 5-year Periods (MW)	9
Table 2	UK Project Configurations	13
Table 3	50 year Metocean Conditions	14
Table 4	Cable Design Considerations	14
Table 5	Required Components for a 495 MW farm (33 x 15 MW turbines)	16
Table 6	Buoyancy Module Parameters	17
Table 7	Buoyancy Modules Required per Lazy Wave by Cable Type	18
Table 8	Summary of Assumptions Used	18
Table 9	Predicted UK FOW Projects by Decade	22
Table 10	Summary of Required Components for 49 GW FOW Baseline Scenario	23
Table 11	Required Interface Components for 49 GW FOW Baseline Scenario	28
Table 12	Number of Required Cable Protection Components for 49 GW FOW Baseline Scenario	30
Table 13	Number of Required Subsea Connectors for 49 GW FOW Baseline Scenario	33
Table 14	UK FOW Deployment scenarios for 75 GW, 100 GW and 150 GW Offshore Wind by 2050	36
Table 15	Summary of Required Components for 29 GW FOW Scenario	37
Table 16	Summary of Required Components for 95 GW FOW Scenario	38
Table 17	Cable and Buoyancy Module Requirements – Aluminium Sensitivity Case	39
Table 18	Cable Requirements – Use of Static Cables Sensitivity Analysis	40
Table 19	Wind Farm Deployment Scenario – Cable Material Sensitivity Analysis	44
Table 20	Wind Farm Deployment Scenario – Static Cable Sensitivity Analysis	45

NOMENCLATURE

AUV	Autonomous Underwater Vehicle
CoE	Centre of Excellence
EEZ	Exclusive Economic Zone
FOSS	Floating Offshore Substation
FOW	Floating Offshore Wind
FOWT	Floating Offshore Wind Turbine
HV	High Voltage
ORE	Offshore Renewable Energy
OSS	Offshore Substation
O&G	Oil and Gas
O&M	Operations and Maintenance
ROV	Remotely Operated Vehicle
TLP	Tension Leg Platform
ULS	Ultimate Limit State

1 INTRODUCTION

Floating offshore wind projects are anticipated to grow in scale around the UK from 2020 to 2035 – from small demonstrator projects to full scale commercial projects. This growth in scale is consistent with the broader growth in offshore wind development in the UK as part of the UK’s efforts to achieve “net zero” by 2050 (and 2045 in Scotland). Dynamic cables, connectors, protection and other ancillary equipment are critical components in floating offshore wind projects. They represent a single point of failure for a turbine (inter-array cable) or the whole project (export cable). In offshore wind more generally, cable technology has not proved to be as reliable as assumed in design and procurement activity. Issues include damage incurred during handling / installation, fatigue failures, manufacturing issues and cable exposure / re-burial.

The dynamic nature of floating offshore wind electrical infrastructure presents an additional challenge to technology designers, manufactures, installers and those responsible for operations and maintenance (O&M). There is an opportunity to work with the supply chain to develop a deeper understanding of the opportunities and challenges associated with cable technology relevant to floating offshore wind. And in turn to ensure that there is a capable, competent and competitive cable technology supply chain who can deliver cost effective and reliable technology at scale. The UK supply chain already has considerable experience associated with dynamic cabling technology, primarily in the oil and gas (O&G) sector. In addition, the UK hosts a number of supply chain organisations which have considerable experience supplying core cable technology to offshore wind.

This report is part of the Floating Offshore Wind Centre of Excellence (FOW CoE) “Dynamic Cabling and Ancillary Systems” project which is being delivered collaboratively by ORE Catapult and Peritus International and builds on analysis performed in the project. Dynamic cabling is a critical component of a FOW project and hence it is vital that project developers have access to robust and reliable technology from the outset. The project aims to develop design methodologies, carry out a focused state of the art review and a programme of technology development and benchmarking directly relevant to UK project development activity. There is also considerable interest in the UK supply chain in the supply of dynamic cable and ancillary components, this project is intended to provide guidance to the supply chain regarding project requirements and stimulate investment in technology and capacity development.

The following report presents anticipated market requirements for dynamic cabling systems and ancillary components in UK FOW projects. This report was commissioned by the FOW CoE to assess and determine credible UK supply chain capacity and capability requirements for key strategic components of FOW projects in the UK, between now and 2050.

1.1 REPORT SCOPE

This report considers inter-array cabling systems and ancillary components for FOW in the UK, between now (2021) and 2050. Export cable requirements are not considered here.

The work presented is intended to provide a best estimate of the future market requirements for dynamic cabling systems. Areas of uncertainty are noted, and some alternative cases are presented. The primary focus is on supply of equipment, but required services are also discussed.

This report does not make an assertion as to the current capability or capacity of the supply chain in specific areas, it purely sets out to estimate the size of the demand on the supply chain in order to deliver dynamic cable systems for UK FOW projects and highlight potential export opportunities.

2 FLOATING OFFSHORE WIND DEPLOYMENT

In this section offshore wind deployment, specifically floating offshore wind deployment, is reviewed for the UK and other key markets around the world. This work has been delivered by the FOW CoE as part of its “Strategic Development of UK Floating Offshore Wind Supply Chain and Infrastructure” project.

2.1 UK

Three offshore wind deployment scenarios of 75 GW, 100 GW and 150 GW in the UK by 2050 were considered. Based on the findings in the FOW CoE report “Strategic Development of FOW Supply Chain and Infrastructure – Deployment Scenarios” the cumulative floating offshore wind deployment was approximated as 29 GW, 49 GW and 95 GW, respectively.

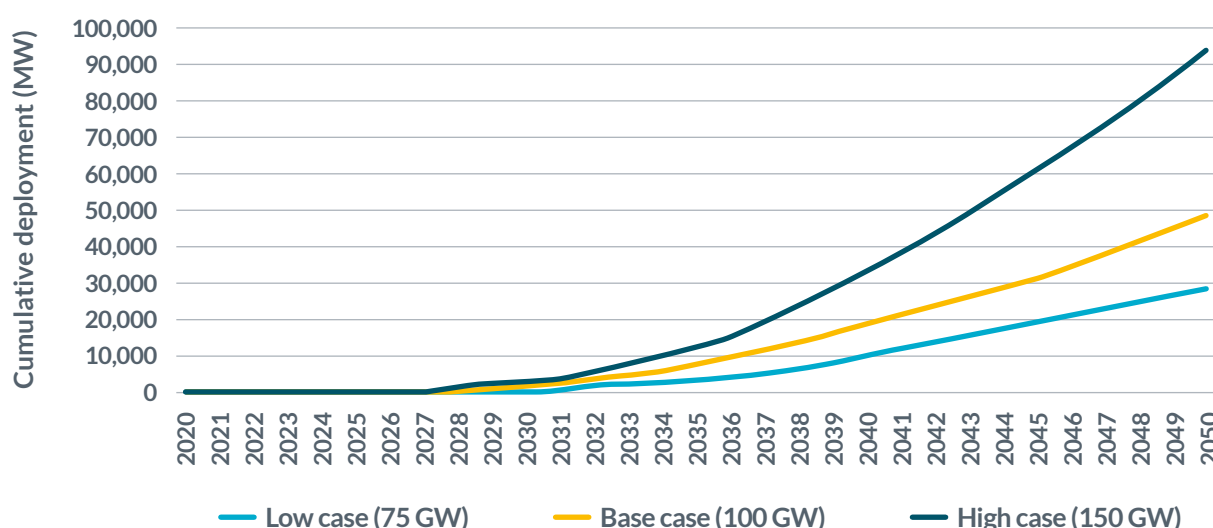

Figure 1: Cumulative Floating Offshore Wind Deployment in the UK between 2020-2050

The ramp up of FOW deployment in the UK aggregated in 5-year periods for the three scenarios considered in the study is shown in Table 1. For all three scenarios, the majority of deployment (85-90%) is estimated to happen between 2036 and 2050.

FOW Deployment Scenario (GW)	to 2025	2026-2030	2031-2035	2036-2040	2041-2045	2046-2050
29	78	396	2,415	7,208	9,500	9,403
49	78	1,896	5,490	10,980	13,212	17,343
95	78	2,396	9,590	20,980	28,252	33,704

Table 1: FOW Deployment to 2050 in 5-year Periods (MW)

The work in this report is primarily based on the 49 GW FOW deployment scenario as a base case.

2.2 REST OF THE WORLD

Based on publicly available information for FOW deployment by country, the total estimated cumulative FOW deployment by 2050 could reach 204 GW. Figure 2 shows deployment by region with the UK having 49 GW (baseline assumption), Europe excluding UK 56 GW, East Asia 68 GW, the USA 24 GW and other countries 7 GW by 2050.

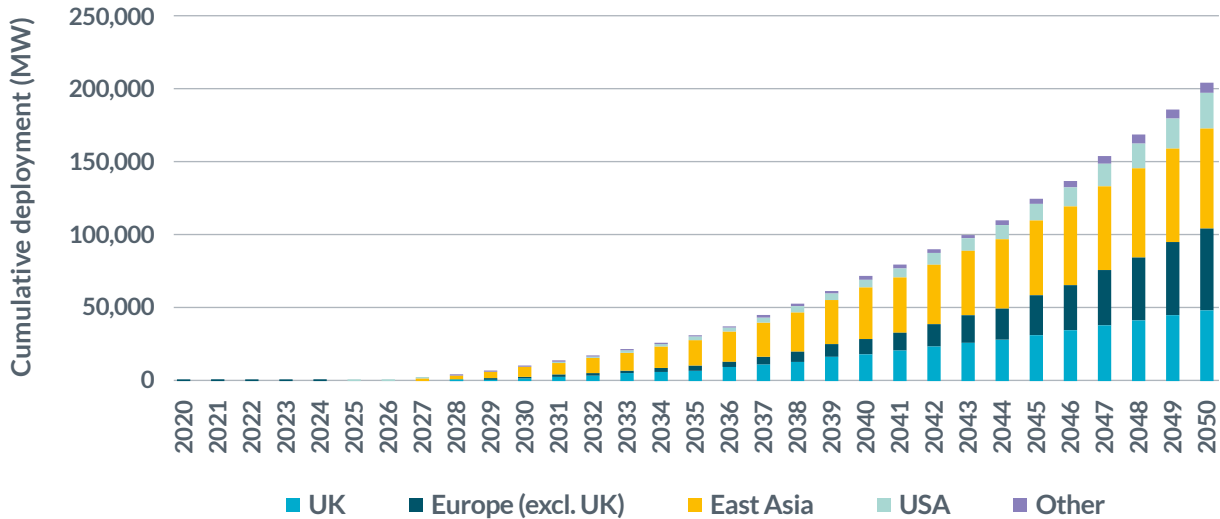

Figure 2: Global Cumulative FOW Deployment

Figure 3 shows the estimated FOW deployment in countries that are the most likely candidates for major FOW component export opportunities. These countries make up 60% of global deployment or 85% if combined with the UK deployment.

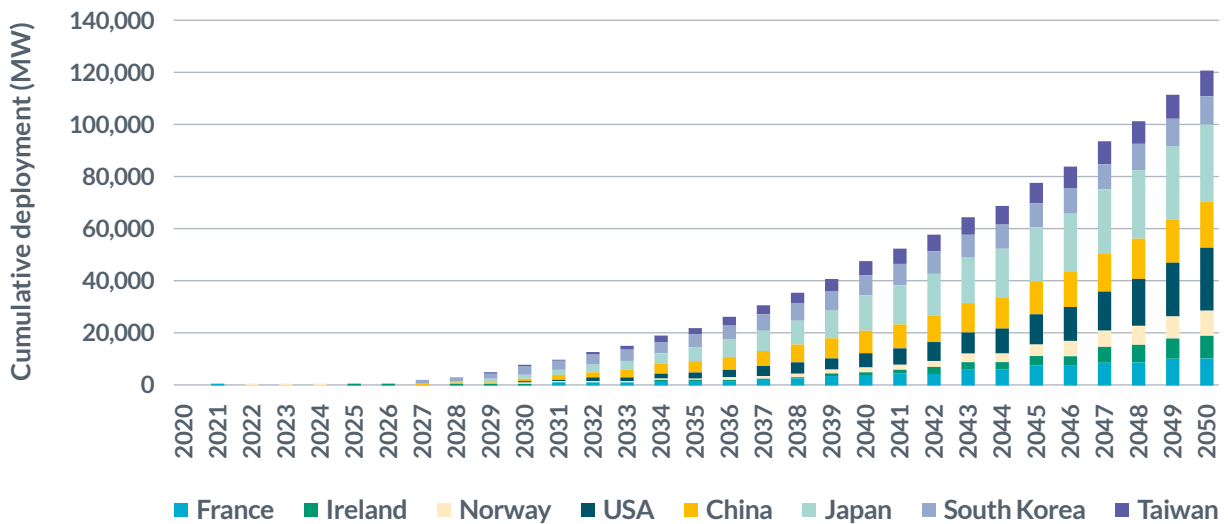

Figure 3: Cumulative FOW Deployment by High Potential Export Country between 2020-2050

Japan is estimated to have 30 GW of FOW by 2050, followed by the USA (24 GW), China (18 GW), South Korea (11 GW), France (10 GW), Norway (10 GW), Taiwan (10 GW) and Ireland (9 GW).

Low potential export markets compared to those in Figure 3 include Spain, Sweden, Finland, India and other countries (e.g. Brazil and Italy). The cumulative deployment for these countries is 34 GW by 2050 as shown in Figure 4.

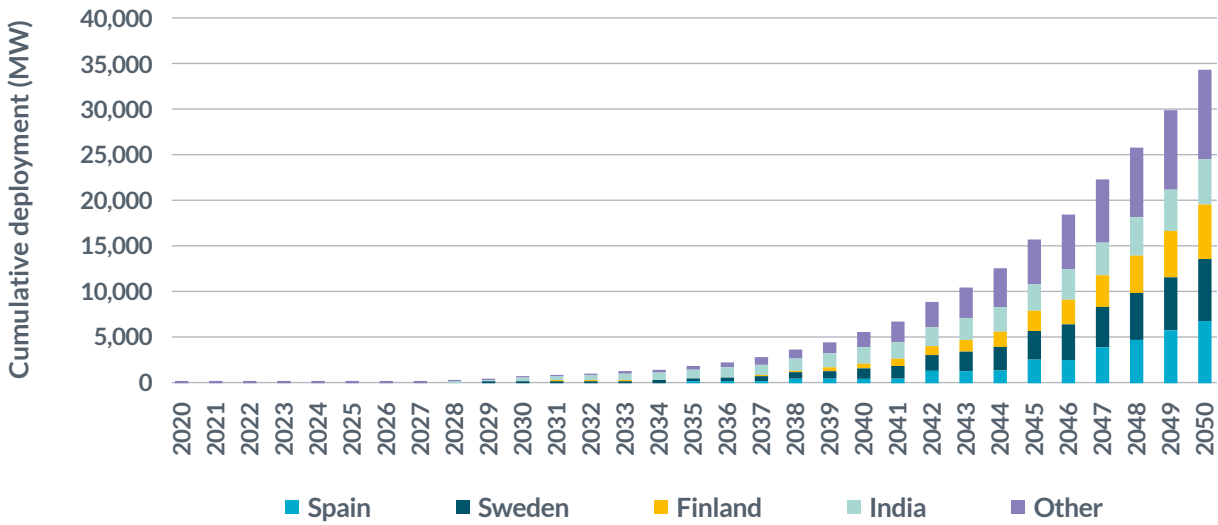

Figure 4: Cumulative FOW Deployment by Low Potential Export Country between 2020-2050

Compared to countries closer to the UK (Ireland, Norway and France) where export of substructures is more likely, the UK’s major FOW specific component export opportunities to the Asian and the USA markets are most likely to be dominated by synthetic mooring ropes and dynamic cables.

3 DYNAMIC CABLE SYSTEMS FOR UK FLOATING WIND

This section of the report details the dynamic cable systems which are expected to be used in UK FOW projects, and the assumptions used to calculate the demand on the supply chain.

3.1 DYNAMIC CABLE SYSTEMS OVERVIEW

The inter-array dynamic cable system used in FOW farms connects FOW turbines to an offshore substation as shown in Figure 5. The system includes the cables themselves plus a range of ancillary components used to connect and protect the cables. The taxonomy or product breakdown structure in Figure 6 details the range of components considered within the inter-array system.

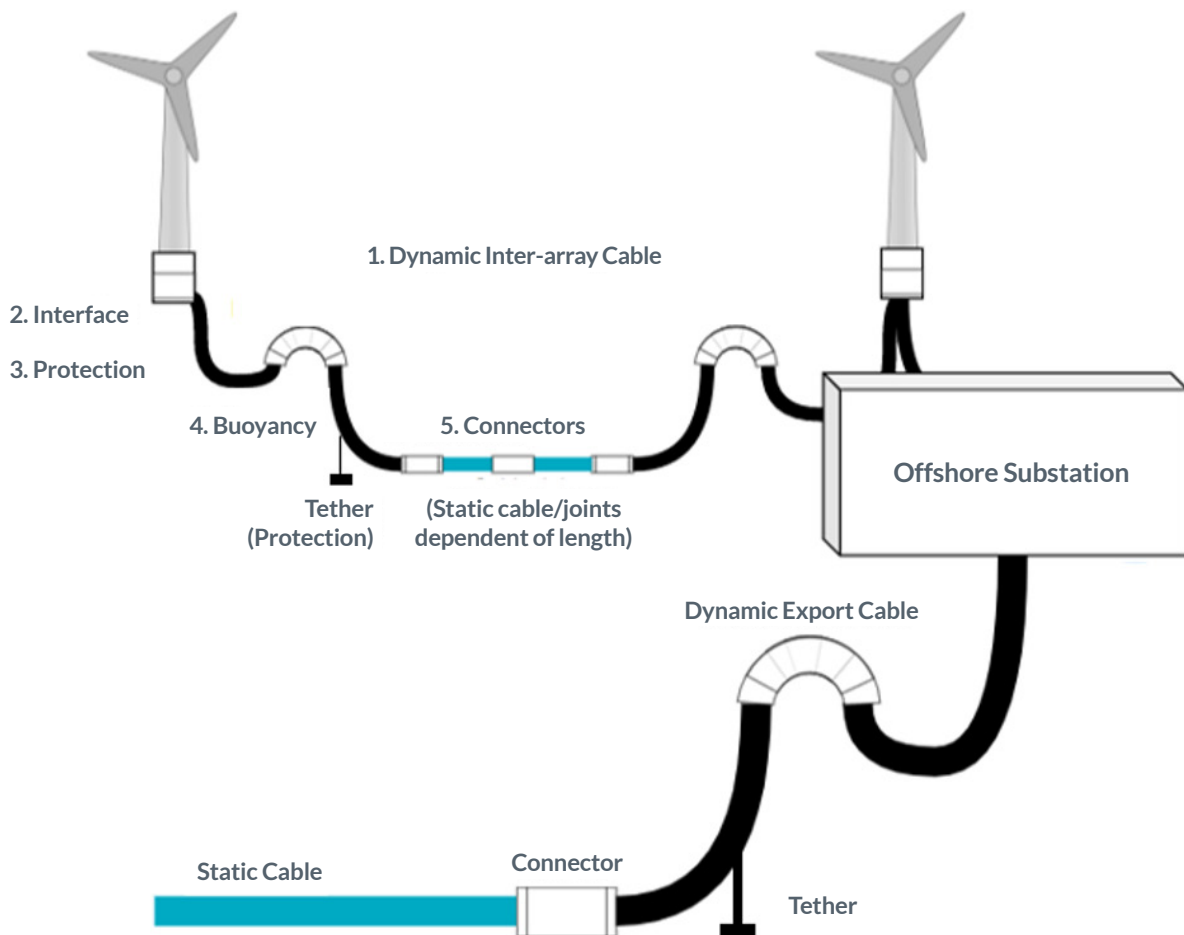

Figure 5: FOW Dynamic Cable System

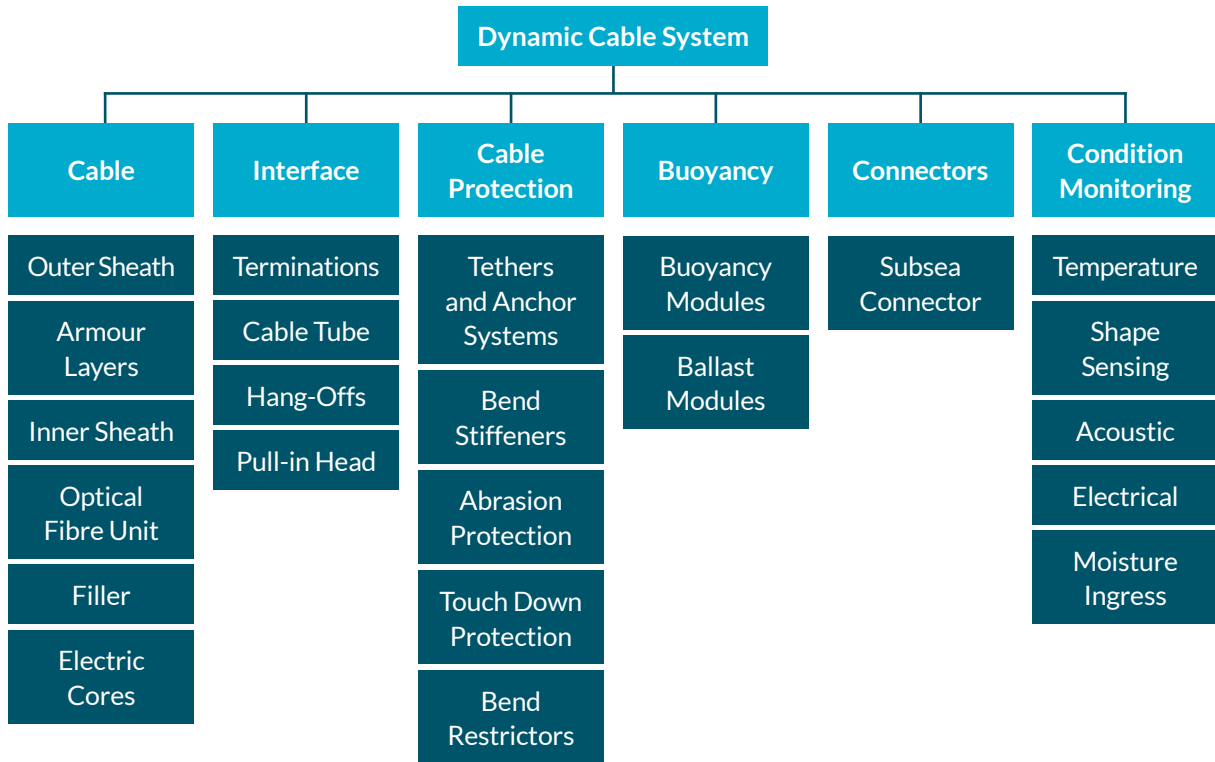

Figure 6: Dynamic Cable System Taxonomy

3.2 UK PROJECT CONFIGURATIONS

As part of the current project, the design requirements for dynamic cable systems in UK FOW project have been assessed. This was carried out by defining a number of potential project configurations, covering a range of conditions expected to be seen in future.

Parameter	Conditions	Notes
Wind farm size	500 MW approx.	Projects have been assumed to be built up in multiple 500 MW stages
Farm voltage	66 kV	Some sensitivity analysis for 132 kV
Turbine rating	15 MW	Sensitivity cases for 18 MW, 20 MW
Floater type	Steel semi-submersible	Expected to be dominant in UK projects
Water depth	60 m, 100 m, 150 m	Covering a range of UK bathymetry
Metocean conditions	'benign', 'moderate', 'exposed'	Primarily based on 50yr Hs for ultimate limit state (ULS) See Table 3
Seabed	Sand or soft clay	Little impact on cable design. Sensitivity on hard seabed
Substation type	Bottom-fixed	Likely for shallow sites and short to medium term until HV dynamic export cables are available

Table 2: UK Project Configurations

Site	Hs (m)	Surface Current (m/s) ¹	Wind speed (m/s)
Benign	10	1.25	35
Moderate	13	1.30	37
Exposed	16	1.05	40

Table 3: 50 year Metocean Conditions

3.3 SYSTEM CONFIGURATION

In addition to the above presented project configurations, a number of additional design criteria were considered when assessing appropriate cable configurations for UK projects. These can be seen in Table 4.

Design Parameter	Requirement / Assumption
Cable material	Copper
Cable type	Wet (for 66 kV base case, 132 kV assumed dry)
Cable size	Based on wind farm layout and voltage
Marine growth	Start and end of life assessment
Mooring excursion	30 – 35% depth, dependent on water depth
Cable burial	UNBURIED; 0.5 M BURIAL
Cable entry location	Centre column base, sensitivity centre column side

Table 4: Cable Design Considerations

3.3.1 FARM LAYOUT

Wind farm layouts have been developed for four different potential wind farms, all around 500 MW capacity:

- A 495 MW wind farm, with 33 15 MW wind turbines and 66 kV inter-array cables
- A 504 MW wind farm, with 28 18 MW wind turbines and 66 kV inter-array cables
- A 500 MW wind farm, with 25 20 MW wind turbines and 66 kV inter-array cables
- A 500 MW wind farm, with 25 20 MW wind turbines and 132 kV inter-array cables

A tapered radial string approach (Figure 7) has been assumed – each turbine except the last in the string has two cables into the base. The cable size is typically reduced farther from the platform. A maximum of two cable sizes per farm have been assumed in this work, but more may be used.

Lateral spacing has been assumed to be five times rotor diameter. Longitudinal spacing has been assumed to be ten times rotor diameter. For the purposes of this study, it is assumed the longitudinal distance from the first turbine in a string to the offshore substation (OSS) is also ten times rotor diameter.

¹ Tidal current + storm surge = surface current. Surface current is lower at the exposed site because the increase in storm surge is less than the decrease in tidal current.

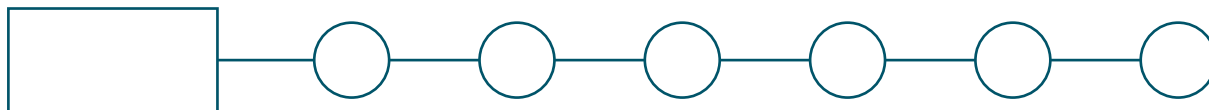

Figure 7: Tapered Radial String (Courtesy of Peritus International)

The wind farm layouts have been used to define dynamic cable lengths and sizes. All 66 kV farms have seven strings, with three to five turbines per string. The 132 kV farm has four strings with six or seven turbines per string.

A small number of 33 kV farms are expected to be deployed in the short term, but for simplicity in this assessment, they are assumed to require the same layout and cable size as the 66 kV case for the same turbine size.

3.3.2 REQUIRED COMPONENTS

A lazy wave configuration has been assumed for all projects (Figure 8). Numerical analysis carried out deemed this to be the most appropriate solution for all project configurations considered. Cable system design for shallow sites with more challenging metocean conditions was challenging and will require optimisation alongside floater and mooring design to control platform motions. It should be noted that only preliminary design has been carried out for indicative purposes. Detailed design will be site, floater and turbine dependent and will result in different cable system design details. For example, cable direction relative to the current flow can impact dynamic behaviour and fatigue performance of the cable. As a result, on some sites a slightly longer cable length and increased capital expenditure could be beneficial over the life of the project via reduced fatigue loading and less risk to the cable.

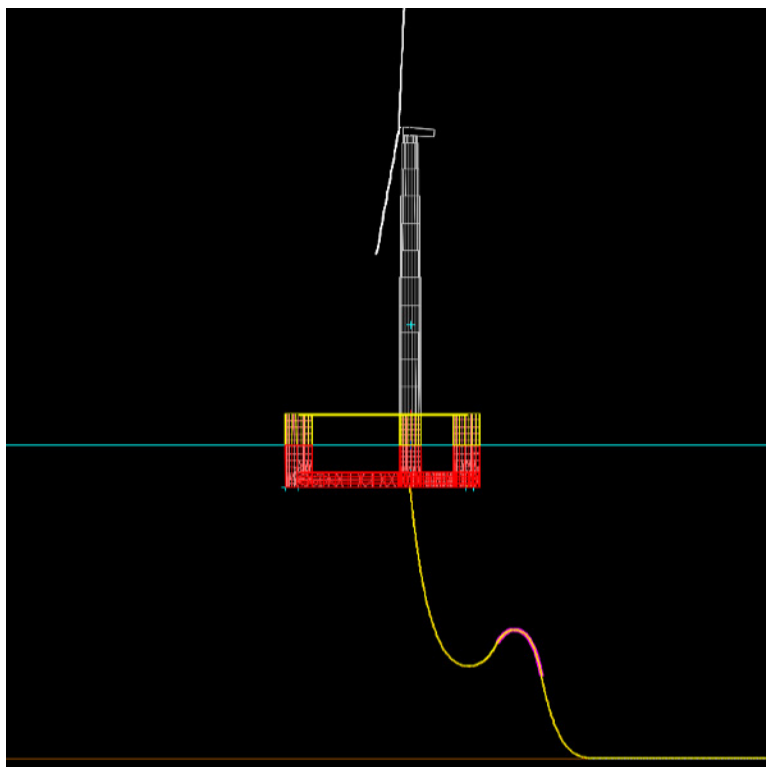

Figure 8: FOW turbine and lazy wave cable configuration (Courtesy: Peritus International)

The full dynamic cable system for one ~ 500 MW farm (assuming 15 MW turbines) requires the components defined in Table 5, split by category as per the taxonomy in Figure 6.

#	Component	Required No.	Notes
1. Cables			
1.1	3 core dynamic power cable, fitted with fibre optic	33 lengths, 2.5 – 4.5 km each 85 – 100 km total	Assumed two cable sizes, dependent on farm layout (e.g. 240 mm ² and 630 mm ² conductor core), Water depth dependent
2. Interface			
2.1	Dynamic hang-off termination assembly for cable	59	For hang-off at lower deck level in floater, one per lazy wave sized according to cable sizes
2.2	Static hang-off termination assembly for cable	7	Dependent on layout, based on number of strings For hang-off at lower deck level on OSS Typically for larger cable size only
2.3	Pigtail termination (size 1)	66	For 3 x electrical cores, with all armour removed 2 per cable (one each end)
2.4	Splice box termination	66	For fibre optic cable, 2 per cable (one each end)
2.5	Pull-in head	59	Same size for all cable sizes Used as installation aid but pre-installed For pull-in to floater deck level, assumed not required at substation end
2.6	Cable tubes	66	To protect cable at exit / entry of floater hang off J-tubes anticipated at substation for static cable sections, I-tubes expected elsewhere Multiple sizes based on cable sizes
3. Cable Protection			
3.1	Dynamic bend stiffener	59	Required for cable entry on floater To include pull-in assembly and seal for I-tube/J-tube cable entry Multiple sizes based on cable size
3.2	Static bend restrictor ²	7	Dependent on layout, based on number of strings For cable entry on OSS, typically larger cable size only To include pull-in assembly and seal for J-tube cable entry

2 At some sites the 'static' entry to the OSS may still have sufficient dynamic loading that a bend stiffener would be more appropriate – in which case this value would be reduced and the number of bend stiffeners would increase.

#	Component	Required No.	Notes
3.3	Cable protection sleeve	59	For abrasion protection at dynamic touchdown point Including straps and fittings Multiple sizes based on cable sizes
3.4	Tethers, holdback clamps or anchors	0 (59 if used)	Not specified in this study, but may be required at sites with high currents or to improve dynamic response
4. Buoyancy			
4.1	Buoyancy modules	578 - 861	Dependent on water depth Based on buoyancy module described in Section 3.3.3 Includes cable clamp, straps, fittings
4.2	Ballast modules	-	Not specified in WP2 Design Requirements report
5. Connectors			
5.1	Subsea connector (wet mate or dry mate)	0 (59 if used)	Not specified in WP2 Design Requirements report Optional to enable tow-to-port, or allow static lengths of cable
6. Condition Monitoring			
16	None specified	-	Not specified but various types likely to be required, dependent on operator / cable designer approach.

Table 5: Required Components for a 495 MW farm (33 x 15 MW turbines)

3.3.3 BUOYANCY DESIGN

The same buoyancy module has been assumed for all project configurations. The below data was used and includes internal clamps, straps and fittings. The buoyancy module has been sized referencing API RP 17L2 Recommended Practice for Flexible Pipe Ancillary Equipment.

Parameter	Unit	Value
Weight in Air	[kgf]	73
Net Buoyancy	[kgf]	103
Buoyancy Factor	-	1.41
Length	[m]	0.9
Diameter	[m]	0.9

Table 6: Buoyancy Module Parameters

The market projections are based on this single size of buoyancy module, but in reality it is likely that a number of different sized buoyancy modules would be used by the industry dependent on project requirements and installation priorities. Larger or smaller buoyancy modules would require fewer or more individual units accordingly. The optimal approach to buoyancy is likely to vary between projects and early engagement with buoyancy suppliers is beneficial. Utilising fewer, larger buoyancy modules can reduce the time, costs and HSE risks associated with installation, but the dynamic performance of the system must be considered. There may be limitations on the maximum size due to clamping forces on the cables, or size limits on the installation vessel.

The figures in Table 7 show the assumed number of buoyancy modules per lazy wave, given the modules chosen. The figures for 240 mm² and 630 mm² copper cable were calculated based on Orcaflex modelling. The other values have been scaled based on cable weight.

Number of Buoyancy Modules per Wave					
Water depth	Cable size and Material				
	240 mm ² Cu	630 mm ² Cu	800 mm ² Cu	400 mm ² Al	1,000 mm ² Al
Shallow (~60 m)	10	17	20	7	10
Mid-depth (~100 m)	12	21	25	8	13
Deep (~150 m)	20	34	40	13	22

Table 7: Buoyancy Modules Required per Lazy Wave by Cable Type

3.4 ASSUMPTIONS

A summary of all technical assumptions used in calculating the projected market requirements are given in Table 8. These include assumptions about site conditions, wind farm and turbine size, as well as more detailed assumptions on the cables and associated components.

Area	Parameter	2021-2025	2026-2030	2031-2035	2036-2040	2041-2045	2046-2050
Site depth	Shallow (60 – 80 m) (% sites)	10%		20%		35%	
	Mid depth (80 – 120 m) (% sites)	80%		60%		30%	
	Deep (120 – 150 m+) (% sites)	10%		20%		35%	
Wind turbine generator	Turbine rating (MW)	15		18	20		
	Rotor diameter (m)	220 ³		240	250		
Wind farm	Turbine longitudinal spacing (m)	2,200		2,400	2,500		
	Turbine lateral spacing (m)	1,100		1,200	1,250		
	Substation max capacity (-)	500 MW					
	Offshore substation type	Fixed offshore substation ⁴					
	Layout	Tapered radial string – see Section 3.3.1					

Area	Parameter	2021-2025	2026-2030	2031-2035	2036-2040	2041-2045	2046-2050
Typology	Semi-submersible / barge (%)	100%					
Cables	Dynamic cables turbine – turbine	100% ⁵					
	Cable lengths	Distance + 2* water depth + 2* water depth + 2*10 m to hangoff					
	Cable size	Dependent on farm layout, 240 mm ² and 630 mm ² or 800 mm ²					
Cable type	Wet (%)	100%		90%		80%	
	Dry (%) ⁶	0%		10%		20%	
Cable voltage	33 kV (%)	20%		5%		0%	
	66 kV (%)	80%		85%		80%	
	132 kV (%)	0%		10%		20%	
Cable material	Copper (%) ⁷	100%					
Buoyancy	Buoyancy modules (No.)	Single size, based on no. waves and type of cable, see Table 7					
Subsea connectors	Sites with no connectors (%)	80%		70%		60%	
	Wet-mate connectors (%)	5%		10%		15%	
	Dry-mate connectors (%)	15%		20%		25%	
Tethers, holdback clamps or anchors	Sites requiring (%)	50%		75%		75%	
Spares	Number of spares required	No assumptions made for spares					

Table 8: Summary of Assumptions Used

3 The turbine used in numerical analysis in this study had a larger rotor than this, but 220 m is assumed to be an average 15 MW rotor diameter.

4 Fixed substations assumed for simplicity, and as dynamic export cables not yet available.

5 Sensitivity case with 80% of farms using dynamic cable in 2031-2040, 70% in 2041-2050.

6 Assume all 132 kV is dry type cable.

7 Sensitivity study with 20% of farms using aluminium in 2021-2030, 40% from 2031-2050.

Site depth – Except for the locations in the far north and north-west of the UK EEZ (European Economic Zone), the majority of the UK seabed applicable to FOW is between 60 m and 150 m water depth. It has been assumed that initially the majority of sites will be built in mid-depth waters, then when the ‘easier’ sites are no longer available wind farms will move into deeper sites farther from shore or shallower sites which are more challenging to engineer for. Dynamic cable systems have been developed for three water depths – 60 m, 100 m and 150 m which are used here for the shallow, mid and deep sites, respectively.

Wind turbine generator – An estimated deployment of large wind turbines was made based on the assumption that the majority of commercial scale farms will utilise 15 MW or larger wind turbines (although ~10 MW may be utilised in the short term for demonstrator and first projects). Numerical analysis was limited to 20 MW turbines.

Rotor diameter – The proposed rotor diameter sizes were based on the assumption that FOW will be installed in locations with strong and consistent winds, which will allow for the planned and existing turbines (e.g. SG 10.0-193 DD, V164-10.0 MW, SG 14-222, V236-15 MW and Haliade-X 14-220) to be further upgraded to higher nameplate capacity.

Turbine spacing – 5 x rotor diameter lateral and 10 x rotor diameter longitudinal spacing has been assumed as an average to calculate inter-array cable lengths. This was chosen as a conservative case in terms of cable sizing, and in future it is foreseeable that developers will seek to have turbines more closely spaced than this. This could reduce the length of cable required.

Substation capacity – A single substation capacity (500 MW) has been assumed in order to allow the design of potential array layouts, including the number of turbines per string and cable sizing. Whilst FOW wind farms may be built out to >1 GW capacity, it is anticipated they will be built as multiple project stages of approximately 500 MW. Larger or smaller substations would impact array layout and potentially the number of turbines per string, which could then impact the required cable size.

Offshore substation type – As high voltage export cables are not yet available then a bottom-fixed substation has been assumed. If replaced by floating substations this would mean a slight increase in cable lengths per farm, plus additional buoyancy modules and potentially additional bend stiffeners in replacement of bend restrictors.

Layout – At this stage, a radial string arrangement has been assumed. Presently this is thought to be the most likely arrangement, though some sites may use star or ring arrangements to reduce the impact of cable failures along a string. This may lead to increased cable requirements in terms of length. In the case of a star arrangement greater quantities of ‘small’ diameter cables could be used, whilst in a ring arrangement there may be a requirement for greater lengths of larger diameter cables.

Typology – Semi-submersibles and barge type substructures were assumed to dominate the UK deployment. Tension Leg Platforms (TLPs) are likely to have a relatively small share of the total deployment and hence have not been included in the analysis. Whilst conventional spars are less likely to be deployed in the UK due to the large draft requirement and lack of ports that can accommodate this, suspended weight spars (e.g. TetraSpar, Telwind and StingerKeel) have reduced draft requirements until installed offshore. However, suspended weight spars are yet to be demonstrated and, as a result of this, were not included in the analysis.

Cable – Dynamic cable has been assumed within the full inter-array system, as transitioning to static cable for short sections between turbines is not anticipated to be cost effective or widely adopted. Joints and connectors may introduce additional points of failure into the system. Cable length and size has been based on preliminary modelling work carried out in WP2 Design Requirements study.

Cable type – A wet cable type is assumed for 33 kV and 66 kV cables, such as the technology currently available in static offshore wind. A wet cable is less susceptible to fatigue and is better suited to dynamic environments. Wet cable designs allow water to migrate into the cable insulation and the conductor and have primarily been developed to remove the requirement for a lead radial water barrier, which was the layer most susceptible to fatigue in a subsea power cable. If this barrier cracks and breaks, then water ingress occurs and can lead to cable failure. These lead barrier layers also increase cable cost and weight and have environmental drawbacks. Corrugated copper sheaths can be used instead for a dry cable design, but these are expensive. Wet cable designs are now typically cheaper as well as lighter and smaller, which also means they are easier to install and require less storage space. The development of higher voltage (e.g. 132 kV) wet cables is a current challenge within the industry, so dry designs have been assumed for any 132 kV cables at this stage.

Cable voltage – The majority of inter-array cables are anticipated to be 66 kV as this is already seen as the norm. A small percentage of 33 kV are anticipated to be used in some initial demonstrator projects, plus spares may be required in coming years. From the 2030s onwards further technical developments in 132 kV cables are expected, with some adoption of these as they become available.

Cable material – At present the most popular cable core material is copper, due to greater fatigue and corrosion resistance and higher conductivity. As such, copper has been assumed to be the cable core material, however, a sensitivity case has looked at the use of both copper and aluminium as this may change dependent on material costs. Aluminium cores and cables need to be larger to transmit the same power.

Buoyancy – The size and number of buoyancy modules has been based on the modelling work carried out in WP2 Design Requirements. The quantity of buoyancy required varies with water depth and cable size. In reality, the size and number of modules required will vary from project to project and dependent on the buoyancy module design. However, the provided figures give a good initial estimate.

Subsea Connectors – Feedback from the industry (developers and the supply chain) has been that currently it is anticipated that the majority of sites will not use subsea connectors, especially in the near future with perhaps more adoption as connector technology is developed and becomes cheaper and more reliable. Of those that do end up using connectors it is expected that most of these would be dry-mate, due to the anticipated large size and high costs of wet-mate connectors.

Whether or not subsea connectors are utilised (on the seabed or at the floating platform) will largely depend on the maintenance strategy adopted. This is an issue still to be decided by the industry and is outside of the scope of this study. To some extent this will be influenced by the connector technology available (although tow-to-port is still feasible without connectors by cutting and splicing the cables). The maintenance strategy adopted will depend on the foreseen time and cost benefits of utilising a connector, as well as the risk profile of the system with or without a connector. It will also be dependent on the distance from port, availability of towing routes and ports for maintenance, the number of major repairs anticipated, and the time required to repair and return to service.

Tethers, holdback clamps or anchors – No tethers or anchors were specified in the system developed as part of WP2 Design Requirements, however, in some of the site conditions analysed the loading in the system was higher than would be desirable and tethers may be useful. There are mixed opinions as to the use of tethers – with some believing them to be a useful tool to manage cable integrity, and others believing them an expensive potential point of failure. At this stage we have assumed that around half of projects may use a tether or similar to begin with, and a greater proportion as projects are built in shallower and/or harsher sites with more current and wave loading on the cable.

Spares – The numbers presented in this work do not account for spares, but it is not unreasonable to anticipate that a 5 – 10 % spares strategy may be adopted, dependent on the items and their cost and lead times. Spares strategies for different components will potentially evolve based on failures seen in service or during installation.

3.5 WIND FARM DEPLOYMENT BASELINE SCENARIO

Using the deployment predictions presented in Section 2.1 and the assumptions presented in Table 8, a baseline scenario has been developed for the FOW projects to be installed each decade, from 2021 – 2050. The percentage figures in Table 8 have been used as a guide to define the number or percentage of projects, rather than to directly define the number of components⁸.

No. of farms	Turbine Size	Voltage	Depth
2021-2030 (1,980 MW, 4 farms)			
1	15 MW * 33 (495 MW)	33 kV	mid
3		66 kV	mid
2031-2040 (16,540MW, 33 farms)			
2	18 MW * 28 (504 MW)	33 kV	mid
2		66 kV	shallow
5			mid
2		deep	
4	20 MW * 25 (500 MW)	66 kV	shallow
11			mid
4			deep
2		132 kV	mid
1			deep
2041-2050 (30,500 MW, 61 farms)			
17	20 MW * 25 (500 MW)	66 kV	shallow
15			mid
17			deep
4		132 kV	shallow
4			mid
4			deep

Table 9: Predicted UK FOW Projects by Decade

⁸ This also means that the total deployed capacity in each decade varies slightly from that presented in Section 2.1, however the variation is very low, less than 1%. For example:

- In 2041 – 2050 the predicted deployment is 30,556 MW, 61 x 500 MW farms are assumed, giving a deployed capacity of 30,500 MW.
- The estimated % of projects using 132 kV cable in 2041 – 2050 is 20%, 20% of 61 farms is 12.2 farms, rounded down to 12.

3.6 LOCAL CONTENT

No assumptions have been made with respect to local content – the figures given are estimations for the full UK FOW requirements.

Estimates based on expected local content can then be extrapolated from these numbers. Typically, a target of 60% local content is used⁹, but this is across a full project and some components and systems may have more or less than this.

The supply chain requires assurance that any local contracting / local content targets proposed by developers at the site award stage will be met further down the line, in order to give them sufficient confidence to make any required investment (e.g. for expansion of production capacity).

⁹ <https://www.gov.scot/publications/offshore-wind-policy-statement/pages/6/>

4 UK MARKET REQUIREMENTS

This section of the report presents the anticipated market requirements based on the above-described deployment scenario. Whilst the component numbers required are likely to vary from project to project, the overall impact on the system LCOE from small changes to capital costs are unlikely to be significant. However, the system design and number of components used will impact the system reliability and have HSE implications, so consideration should be made beyond minimising system cost.

4.1 REQUIRED COMPONENTS

The quantities of components required by decade and in total are summarised in Table 10.

Item	unit	2021-2030	2031-2040	2041-2050	Total
Cable lengths (copper)	#	132	858	1,525	2,515
Cables (copper)	km	367	2,665	4,777	7,809
33 kV (wet) cable		92	169	0	261
240 mm ²		55	79	0	134
630 mm ²		37	90	0	127
66 kV (wet) cable		275	2,268	3,886	6,429
240 mm ²		165	1,135	2,013	3,313
630 mm ²		110	408	0	518
800 mm ²		0	725	1,873	2,598
132 kV (dry) cable		0	227	892	1,119
240 mm ²		0	179	704	883
630 mm ²		0	48	188	235
Buoyancy modules	No.	3,444	26,258	48,693	78,395
Dynamic bend stiffeners ¹⁰	No.	236	1,494	2,659	4,389
Static bend restrictors	No.	28	222	391	641
Dynamic hang-off termination	No.	236	1,494	2,659	4,389
Static hang-off termination	No.	28	222	391	641
Pigtail termination connection	No.	264	1,716	3,050	5,030
Splice box termination kit	No.	264	1,716	3,050	5,030
Cable protection sleeve	No.	236	1,494	2,659	4,389
Pull-in head	No.	236	1,494	2,659	4,389
I-tube (or J-tube, or bellmouth)	No.	236	1,494	2,659	4,389

¹⁰ Also requires bend stiffener connector assemblies.

Item	unit	2021-2030	2031-2040	2041-2050	Total
J-tube	No.	28	222	391	641
Tethers or anchors	No.	118	1,086	2,005	3,209
Subsea connectors – wet-mate	No.	0	135	393	528
Subsea connectors – dry mate	No.	0	270	654	924

Table 10: Summary of Required Components for 49 GW FOW Baseline Scenario

4.1.1 CABLE

The required inter-array cable lengths are detailed by voltage and size in Table 10. Two cable conductor sizes per farm have been assumed; 240 mm² in conjunction with 630 mm² or 800 mm² has been used throughout.

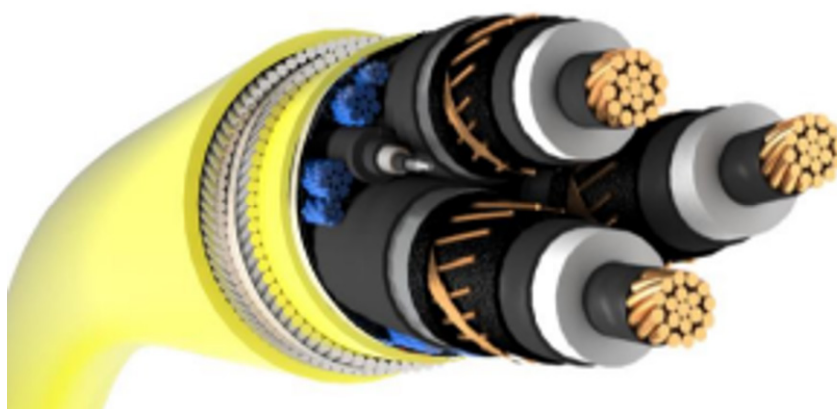

Figure 9: Dynamic Cable (Courtesy: JDR Cable Systems)

One length of cable is required per turbine, so for the circa. 500 MW farms considered each requires 25 to 33 individual cable lengths.

The length of single cable sections ranges from 2,400 m to 4,977 m. This is a conservative case given the 10 x rotor diameter longitudinal spacing assumption and could be reduced if turbines are spaced more closely.

For the 15 MW farms and 132 kV 20 MW farms the majority of cable required is with the smaller conductor size (240 mm²). The 66 kV farms with 18 MW and 20 MW turbines still require a greater quantity of the smaller cable, but the split is closer to 50:50 between cable sizes.

The total cable length required per ~500 MW farm ranges from approximately 75 to 98 km for a 66 kV farm, and from 70 to 79 km for a 132 kV farm. This is primarily because the number of turbines which can be placed on a higher voltage string increases.

As part of the cable production process production and assembly of the following individual parts are required for conventional dynamic cable designs:

- Electrical cores (3 per cable), with conductor, electrical insulation, and protective layers
- Optical fibre, within a stainless steel optical fibre tube
- Fillers
- Armour wire, for double (or quad) armour layer
- Sheaths

Cables will typically be provided with a section of the conductor cores with outer packaging stripped away – ‘pigtailed’. These ends are then typically protected with a pull-in head. Around five to ten metres of cable is usually left without armour wire, as removal of armouring offshore during installation is complex and time consuming. Temporary armour or protection may be applied at cable ends for pre-lay, to be removed upon connection with the platform.

4.1.2 INTERFACE

The required interface components are shown in more detail in Table 11.

The dynamic and static hang-off termination assemblies, also known simply as hang-off clamps, are installed at the point where the cable connects to the floater (dynamic hang-off) or OSS (static hang-off) and the tensile load is transferred through this assembly. Typically this assembly includes a number of components – a collar will grip the outside of the cable, the cable armour wires will be split out and anchored to a flanged assembly. As double armouring layers will be used often there will be a double flanged assembly.



Figure 10: Cable hang-off clamp (Courtesy: Tekmar)¹¹

As the static hang-off assemblies are required only for the cables connecting into the OSS, these are only required for larger diameter cables. If a FOSS was used this would remove the requirement for static hang-offs and increase the required number of dynamic hang-offs accordingly.

The pigtail termination connector kit is used to connect the cable conductor core pigtails into the electrical switchgear above the hang-off assembly. Not described in the table are inline or tee connections at switchgear which the terminations would connect into. The requirements for these are not expected to vary from static projects.

¹¹ <https://www.tekmar.co.uk/product/>

The splice box termination connector kit will perform the same function as the pigtail termination connectors, but for fibre optic cables. One fibre optic per dynamic cable has been assumed in this study.

The pull-in heads are an installation aid, used to house and protect the cable pigtails whilst cables are pre-laid and during the installation and connection process. They will typically be supplied by the cable vendor with the power cable. Following installation these will be cut-off and could be inspected for potential re-use on other projects. For the purposes of this study no re-use has been assumed, and new pull-in heads for every cable are provisioned for. Pull-in heads are typically sized by tensile loads and one size is expected to be suitable for most projects.

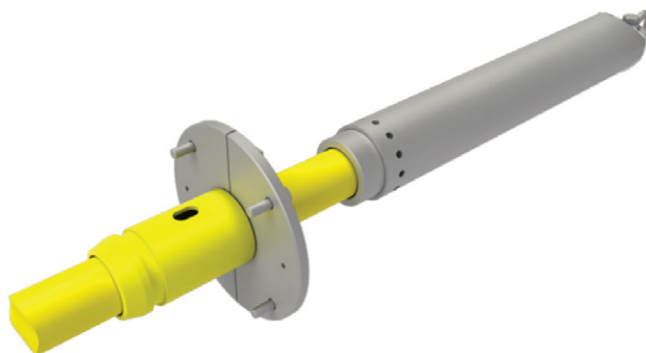

Figure 11: Pull-in head (Courtesy: Oceaneering)¹²

I-tubes and J-tubes are structural components typically provided with the floater by the platform contractor. They tend to be sized to 2-3 times the dynamic cable diameter. A J-tube will be connected to the static hang-off termination assembly at the OSS with a flanged connection and will protect the cable. I-tubes will be similarly connected to dynamic hang-off terminations on the floater. J-tubes or bellmouths can be alternatively used but I-tubes are most common.



Figure 12: Cable J-tube (Courtesy: Optimus Aberdeen)¹³

¹² <http://www.oceaneering.com/datasheets/SDS-Pull-in-and-Hang-Off-Systems-A4.pdf>

¹³ <https://optimusaberdeen.com/case-studies/offshore-wind-j-tube-installation>

Item	Cable Voltage	Cable Size	2021-2030	2031-2040	2041-2050	Total
Dynamic hang-off termination assembly	Total		236	1,494	2,659	4,389
	33 kV	<i>Subtotal</i>	59	98	0	157
		240 mm ²	42	56	0	98
		630 mm ²	17	42	0	59
	66 kV	<i>Subtotal</i>	177	1,258	2,107	3,542
		240 mm ²	126	784	1,372	2,282
		630 mm ²	51	189	0	240
		800 mm ²	0	285	735	1,020
	132 kV	<i>Subtotal</i>	0	138	552	690
		240 mm ²	0	120	480	600
630 mm ²		0	18	72	90	
Static hang-off termination assembly	Total		28	222	391	641
	33 kV	<i>Subtotal</i>	7	14	0	21
		630 mm ²	7	14	0	21
	66 kV	<i>Subtotal</i>	21	196	343	560
		630 mm ²	21	63	0	84
		800 mm ²	0	133	343	476
	132 kV	<i>Subtotal</i>	0	12	48	60
		630 mm ²	0	12	48	60
Pigtail termination connector kit	Total		264	1,716	3,050	5,030
	33kV	<i>Subtotal</i>	66	112	0	112
		240 mm ²	42	56	0	56
		630 mm ²	24	56	0	56
	66 kV	<i>Subtotal</i>	198	1,454	2,450	3,904
		240 mm ²	126	784	1,372	2,156
		630 mm ²	72	252	0	252
		800 mm ²	0	418	1,078	1,496
	132 kV	<i>Subtotal</i>	0	150	600	750
		240 mm ²	0	84	480	564
630 mm ²		0	66	120	186	
Splice box termination connector kit for fibre optic cable	All	All	236	1,494	2,659	4,389

Item	Cable Voltage	Cable Size	2021-2030	2031-2040	2041-2050	Total
Pull-in head	All	All	236	1,494	2,659	4,389
I-tube, J-tube or Bellmouth for dynamic cable entry to floater	All	<i>Subtotal</i>	236	1,494	2,659	4,389
		240 mm ²	168	960	1,852	2,980
		630 mm ²	68	249	72	389
		800 mm ²	0	285	735	1,020
J-tube for dynamic cable entry to OSS	All	<i>Subtotal</i>	28	222	391	641
		630 mm ²	28	89	294	411
		800 mm ²	0	133	84	217

Table 11: Required Interface Components for 49 GW FOW Baseline Scenario

4.1.3 CABLE PROTECTION

Table 12 details the required cable protection components by decade and split by size.

Dynamic bend stiffeners (Figure 13) and static bend restrictors are connected to I-tubes and J-tubes respectively using cable-entry connector assemblies. These connect the bend stiffener and cable tube and are complex steel and polymer assemblies made of several dozen pieces.



Figure 13: Bend Stiffener (Courtesy: Kaylan Offshore)¹⁴

In this study cable protection sleeves (Figure 14) have been specified for abrasion protection (Figure 14) at the touchdown point only, but some systems may also use protection sleeves along the length of the cable on the seabed which would increase these requirements.

¹⁴ <https://www.kaylanoffshore.co.uk/kaylan-products/polyurethane-bend-stiffener>

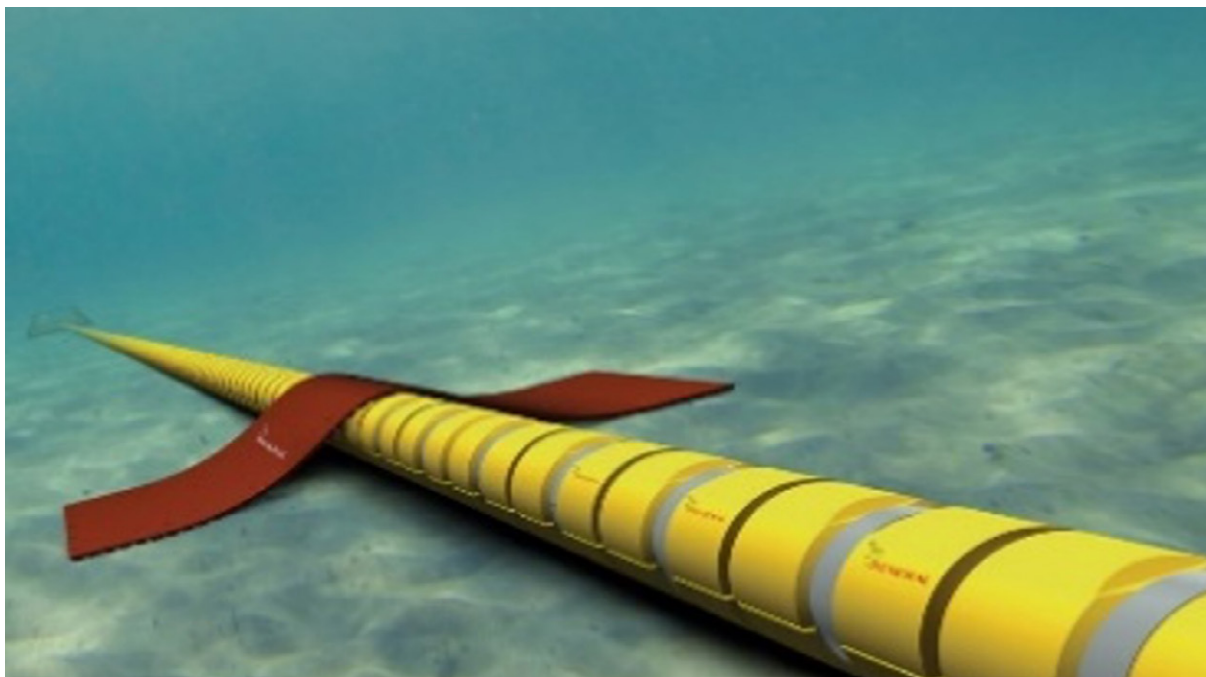

Figure 14: Abrasion Protection (Courtesy: Balmoral Offshore)¹⁵

Item	Cable Size	2021-2030	2031-2040	2041-2050	Total
Dynamic Bend stiffener and cable-entry connector assembly	<i>Subtotal</i>	236	1,494	2,659	4,389
	240 mm ²	168	960	1,852	2,980
	630 mm ²	68	249	72	389
	800 mm ²	0	285	735	1,020
Static bend restrictor and cable-entry connector assembly	<i>Subtotal</i>	28	222	391	641
	630 mm ²	28	89	294	411
	800 mm ²	0	133	84	217
Touchdown protection sleeve	<i>Subtotal</i>	236	1,494	2,659	4,389
	240 mm ²	168	960	1,852	2,980
	630 mm ²	68	249	72	389
	800 mm ²	0	285	735	1,020
Tethers or anchors	All	118	1,086	2,005	3,209

Table 12: Number of Required Cable Protection Components for 49 GW FOW Baseline Scenario

¹⁵ <https://www.balmoraloffshore.com/solutions/protection/cable-pipeline-protection>

4.1.4 BUOYANCY AND BALLAST MODULES

As described previously, only one size of buoyancy module has been used in the calculated projections, but in reality a range of sizes will be used across wind farms to create the lazy wave shape in the cable. As buoyancy module size changes the number required will increase or decrease accordingly. An example of cross-section of a buoyancy module is shown in Figure 15.



Figure 15: Buoyancy module cross-section (Courtesy: Balmoral Offshore)

The system defined for this study did not specify the use of ballast modules but the potential requirement for these should be considered. Clamp-on ballast modules can be used in the upper section of a lazy wave to limit cable compression in extreme environmental conditions, and possibly prevent clashing. Improving the response in some environmental conditions can, however, worsen the response in other conditions.

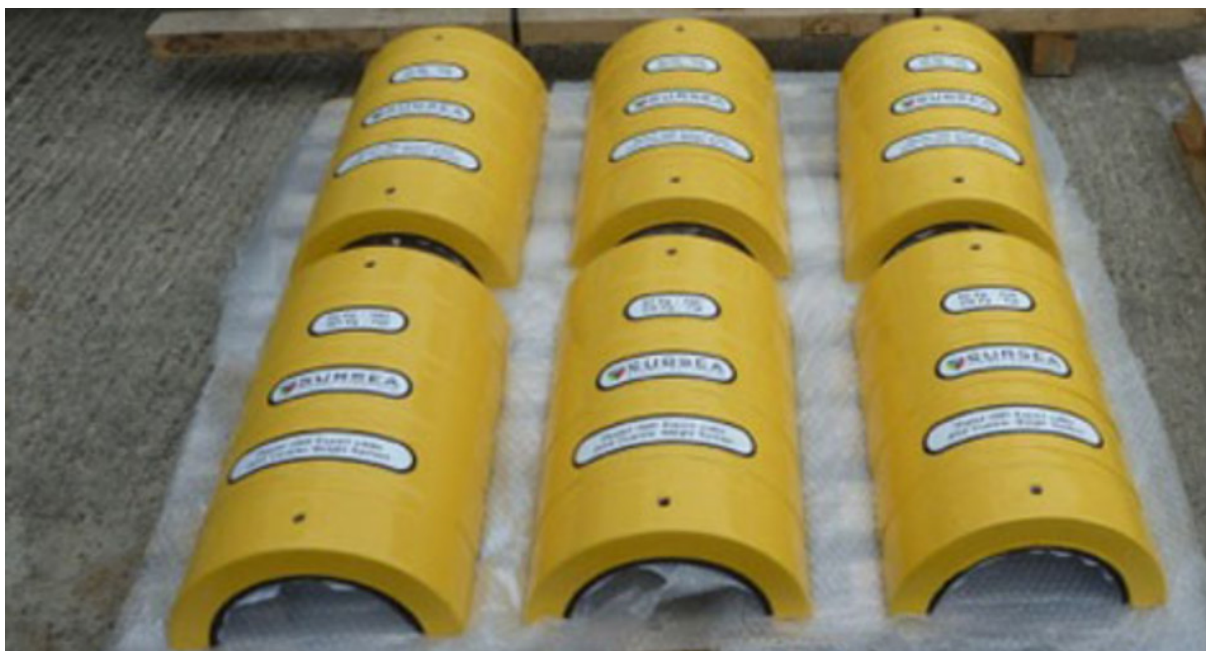

Figure 16: Ballast Modules (Courtesy: Subsea Energy Solutions)¹⁶

Ballast modules can in principle also be used to improve the cable response in the touchdown region although this type of application is seldom used and not as well understood. Ballast modules, if used, would be placed away from the buoyancy module section of a lazy wave. Ballast modules have a similar clamp-on design to distributed buoyancy modules but are usually more compact (smaller dimensions). A dynamic cable design should remove as much conservatism from the analysis of the environmental loading before considering ballast modules and for that reason, ballast modules are not often proposed.

¹⁶ <https://www.subenesol.co.uk/Products/SUB-BALLAST-Cable-Ballast-Modules>

4.1.5 CONNECTORS

Predicted required quantities of wet-mate and dry-mate subsea connectors split by cable voltage and cable size are given in Table 13. As described in the assumptions, the adoption of connectors remains to be seen and will be dependent on the adopted maintenance strategy, analysis of which is out of scope of the current study.

These connectors would be used at the seabed to connect lengths of cable; either enabling disconnection for tow-to-port maintenance of floaters, or to enable the use of lengths of static cable between floaters. The latter is not currently anticipated to be widely adopted due to the expected distances between turbines. Alternatively, connectors may be used at the platform end of the dynamic cable system, rather than at the seabed, again to enable easy hook-up / disconnection for tow-to-port maintenance.

Wet-mate connectors can be connected and disconnected subsea, whilst dry-mate connectors require retrieval and lifting above the water surface before connection or disconnection.



Figure 17: Wet Mate Connector (11kV) (Source: MacArtney)¹⁷

Break-away connectors are an additional type of connector being considered as protection of the system – designed to break away at a given load following platform drift-off these would protect the rest of the electrical system from failure. The development and uptake of these components are yet to be well understood and so no projections are made at this point.

¹⁷ https://www.macartney.com/media/4615/renewable-presentation_07062016.pdf

Item	Cable Voltage	Cable Size	2021-2030	2031-2040	2041-2050	Total
Dry-mate connectors	Total		0	270	654	924
	33 kV	<i>Subtotal</i>	0	0	0	0
		240 mm ²	0	0	0	0
		630 mm ²	0	0	0	0
	66 kV	<i>Subtotal</i>	0	270	516	786
		240 mm ²	0	168	336	504
		630 mm ²	0	42	0	42
		800 mm ²	0	60	180	240
	132 kV	<i>Subtotal</i>	0	0	138	138
		240 mm ²	0	0	120	120
630 mm ²		0	0	18	18	
Wet-mate connectors	Total		0	135	393	528
	33 kV	<i>Subtotal</i>	0	0	0	0
		240 mm ²	0	0	0	0
		630 mm ²	0	0	0	0
	66 kV	<i>Subtotal</i>	0	135	301	436
		240 mm ²	0	84	196	280
		630 mm ²	0	21	0	21
		800 mm ²	0	30	105	135
	132 kV	<i>Subtotal</i>	0	0	92	92
		240 mm ²	0	0	80	80
630 mm ²		0	0	12	12	

Table 13: Number of Required Subsea Connectors for 49 GW FOW Baseline Scenario

4.1.6 CONDITION MONITORING

As listed in the taxonomy in Figure 6, a number of potential condition monitoring systems are likely to be required for deployment in inter-array dynamic cable systems. Mechanical and electrical health of the system are expected to be monitored both within cable lengths and at connections and terminations.

Common condition monitoring technologies are detailed below.

- Distributed temperature sensing (DTS) utilises fibre optic cable that is already integrated into the cable, and monitors the cable temperature along its length;
- Distributed acoustic sensing (DAS) utilises fibre optic cable that is already integrated into the cable, and can detect cable obstructions e.g. due to dropped objects. DTS and DAS can be used in combination to identify cable ageing;

- Partial discharge (PD) monitoring, which requires additional hardware. When carried out continuously (online) early warning of insulation damages caused from partial discharge can be detected, as well as increasing the understanding of cable response to loads and temperatures;
- Line impedance resonance analysis (LIRA) can detect cable degradation due to a range of reasons (e.g. impact, moisture ingress, temperature damage). This is currently performed offline but in-situ; online LIRA monitoring has been demonstrated on onshore sites but not yet demonstrated offshore at 33 kV or higher;
- Power quality (PQ) monitoring requires additional hardware and can monitor voltage drops and other aspects of the power quality such as flicker and oscillations. This could be performed at the substation or at each turbine;
- Visual inspection via ROV to monitor cable position;
- Direct measurement of cable position or movement using inclinometers on the cable or bend stiffener to measure cable angle and elevation at the platform interface. Alternatively, accelerometers or curvature sensors could be used;
- Inferred cable motion monitoring via platform position and angle monitoring using Global Positioning Systems (GPS) or Motion Reference Units (MRUs), or by using hydrophones or sonar to record distance between cable and platform.

Many of these have been proven for bottom-fixed wind and theoretically will work for dynamic cables but are yet to be widely demonstrated or tuned to floating applications. The number and volume of systems required will be dependent on monitoring strategies adopted by developers and cable manufacturers. Whilst not quantified in this report, these can be approximated based on the volumes of cables and connections described above.

4.2 REQUIRED SERVICES

In addition to the above described components, it is important to consider the market requirements in terms of services related to dynamic cabling and ancillary systems. These will be described a high level in the following section. These are not projected at a certain scale but the annual deployment predictions in Section 2, and the number of projects predicted in Section 3.5 can be used to guide the scale of supply needed.

4.2.1 ENGINEERING AND DESIGN

The following engineering and design activities will be required for FOW dynamic cabling systems in order to enable the predicted scale of deployment.

4.2.1.1 Site Investigation

Although not directly related to cable design, as it will be carried out as part of wider engineering activities, site investigation and characterisation works are essential to enable cable system design. This includes understanding bathymetry, metocean conditions, and seabed conditions via surveys and data analysis.

4.2.1.2 System Design

Each project is expected to require a bespoke system design to some extent. Even two projects from the same developer with the same floater and turbine design will have different site conditions, and lessons will be learnt from previous projects. Consultancies and engineering firms are required to undertake design and analysis using simulation software and utilising prior knowledge.

4.2.1.3 Component Design

Whilst cable designs are converging and there is a standard range of conductor sizes, it is currently expected that each project will require a bespoke cable cross sectional arrangement, including conductors, fillers, armour and sheathing. This requires design and validation work from cable manufacturers and engineering firms.

There are also a number of ancillary components (such as hang-off assemblies and entry connector assemblies) that are likely to be designed bespoke to each project. Similarly with bend stiffeners which are very dependent on cable design. Buoyancy modules are more likely to be off-the-shelf components.

4.2.1.4 Research, Qualification and Testing

The predictions presented in this report include a number of components not yet on the market – 132 kV dynamic cables, wet mate connectors for example. Research and development activity is required to design these new components. These new components will also then require testing and qualification.

Qualification is also likely to be required for new systems and subsystems which may not include such significant step changes in technology but where new designers enter the market or a new combination of components is deployed together.

Additionally, currently cable designs are all validated for specific site conditions on a project by project basis in addition to the type qualification and testing carried out. This may reduce over time as the industry matures and there is more confidence in the design and analysis process.

4.2.2 SUPPLY

Companies will be required to supply the items described in Section 4.1 above – either the full system or components of the system. Components could come directly from the manufacturer or a third party vendor could be used to source and supply multiple parts of the system.

4.2.3 INSTALLATION

Installation contractors and cable lay vessels will be required for cable pre-laying (with pre-trenching or simultaneous trenching for buried cables), as well as cable hook up to the floater platform.

Installation aids and accessories such as winches may be required.

4.2.4 OPERATIONS AND MAINTENANCE

Inspection and maintenance services will be required throughout the cable life. For inspection autonomous underwater vehicles (AUVs) or remotely operated vehicles (ROVs) could be utilised. Maintenance requirements could include cable change out or repair, which would require cable lay vessels.

5 UK MARKET REQUIREMENTS SENSITIVITY ANALYSIS

This section of the report discusses some alternative market projections and other sensitivity studies.

5.1 FOW DEPLOYMENT VARIATION

One of the primary sources of uncertainty is the FOW deployment figures. The market projections presented in Section 4 are for ORE Catapult’s ‘baseline’ scenario of 100 GW offshore wind in the UK by 2050, however, two alternative scenarios for 75 GW and 150 GW were presented in Section 2. Table 14 shows the predicted FOW deployment for each of these scenarios.

The 75 GW (29 GW FOW) and 150 GW (95 GW FOW) scenarios are considered in this section.

Offshore Wind by 2050	2021-2030	2031-2040	2041-2050	Total
Predicted FOW Deployment (MW)				
75 GW	396	9,623	18,903	28,922
100 GW	1,896	16,470	30,556	48,922
150 GW	2,396	30,570	61,956	94,922

Table 14: UK FOW Deployment scenarios for 75 GW, 100 GW and 150 GW Offshore Wind by 2050

5.1.1 75 GW UK OFFSHORE WIND

Table 15 includes a summary of required components for the 75 GW offshore wind, 29 GW FOW scenario.

Item	unit	2021-2030	2031-2040	2041-2050	Total
Cables - copper	km	92	1,523	2,978	4,593
33 kV (wet) cable		0	85	0	85
240 mm ²		0	39	0	39
630 mm ²		0	45	0	45
66 kV (wet) cable		92	1,286	2,383	3,760
240 mm ²		55	648	1,235	1,938
630 mm ²		37	181	0	218
800 mm ²		0	456	1,148	1,605
132 kV (dry) cable		0	153	595	748
240 mm ²		0	121	470	590
630 mm ²		0	32	125	157
Buoyancy modules	No.	861	14,889	30,689	46,439
Dynamic bend stiffeners	No.	59	853	1,658	2,570
Static bend restrictors	No.	7	127	242	376
Dynamic hang-off termination	No.	59	853	1,658	2,570
Static hang-off termination	No.	7	127	242	376
Pigtail termination connection	No.	66	980	1,900	2,946
Splice box termination kit	No.	66	980	1,900	2,946
Cable protection sleeve	No.	59	853	1,658	2,570
Pull-in head	No.	59	853	1,658	2,570
I-tube (or J-tube, or bellmouth)	No.	59	853	1,658	2,570
J-tube	No.	7	127	242	376
Tethers or anchors	No.	30	675	1,265	1,970
Subsea connectors – wet-mate	No.	0	86	261	347
Subsea connectors – dry mate	No.	0	178	436	614

Table 15: Summary of Required Components for 29 GW FOW Scenario

5.1.2 150 GW UK OFFSHORE WIND

Table 16 includes a summary of required components for the 150 GW offshore wind, 95 GW FOW scenario.

Item	unit	2021-2030	2031-2040	2041-2050	Total
Cables - copper	km	458	4,835	9,710	15,003
33 kV (wet) cable		92	169	0	261
240 mm ²		55	79	0	134
630 mm ²		37	90	0	127
66 kV (wet) cable		367	4,291	7,851	12,509
240 mm ²		220	2,148	4,067	6,435
630 mm ²		146	769	0	916
800 mm ²		0	1,374	3,784	5,158
132 kV (dry) cable		0	375	1,859	2,234
240 mm ²		0	296	1,467	1,763
630 mm ²		0	79	392	470
Buoyancy modules	No.	4,305	47,229	99,315	150,849
Dynamic bend stiffeners	No.	295	2,755	5,407	8,457
Static bend restrictors	No.	35	409	793	1,237
Dynamic hang-off termination	No.	295	2,755	5,407	8,457
Static hang-off termination	No.	35	409	793	1,237
Pigtail termination connection	No.	330	3,164	6,200	9,694
Splice box termination kit	No.	330	3,164	6,200	9,694
Cable protection sleeve	No.	295	2,755	5,407	8,457
Pull-in head	No.	295	2,755	5,407	8,457
I-tube (or J-tube, or bellmouth)	No.	295	2,755	5,407	8,457
J-tube	No.	35	409	793	1,237
Tethers or anchors	No.	177	2,077	1,919	4,173
Subsea connectors – wet-mate	No.	0	270	829	1,099
Subsea connectors – dry mate	No.	0	540	1,363	1,962

Table 16: Summary of Required Components for 95 GW FOW Scenario

5.2 CABLE MATERIAL

Another sensitivity case is the use of alternative materials. In the following case it has been assumed that 20% of farms use aluminium in 2021-2030, and 40% use aluminium from 2031 – 2050. The remaining cables are copper as in the baseline study. The revised deployment scenario is shown in Appendix 1 (Table 19).

Table 17 shows updated projected requirements for cables and buoyancy modules, assuming a split between copper and aluminium cables. Fewer buoyancy modules are required due to lighter aluminium cables. Total requirement on cable is the same, but split between more materials and sizes – potentially making providing these items more complex for the supply chain.

The numbers of ancillary components such as interface connections and cable protection are not shown. High level totals required are the same, but again the split of sizes will differ with more different sizes required.

Item	unit	2021-2030	2031-2040	2041-2050	Total
Cables (copper)	km	275	1,613	2,495	4,383
33 kV (wet) cable		92	169	0	261
240 mm ²		55	79	0	134
630 mm ²		37	90	0	127
66 kV (wet) cable		183	1,291	1,900	3,374
240 mm ²		110	647	1,191	1,948
630 mm ²		73	224	0	298
800 mm ²		0	420	709	1,129
132 kV (dry) cable		0	153	595	748
240 mm ²		0	121	470	590
630 mm ²		0	32	125	157
Cables (aluminium)	No.	92	1,047	2,026	3,165
33 kV (dry) cable		0	0	0	0
400 mm ²		0	0	0	0
1000 mm ²		0	0	0	0
66 kV (dry) cable		92	973	1,729	2,794
400 mm ²		55	487	822	1,363
1000 mm ²		37	181	0	218
1000+ mm ²		0	306	907	1,213
132 kV (dry) cable		0	74	297	371
400 mm ²		0	58	234	293
1000 mm ²		0	16	63	78
Buoyancy modules	No.	3,140	22,103	41,111	66,354

Table 17: Cable and Buoyancy Module Requirements – Aluminium Sensitivity Case

5.3 USE OF STATIC CABLES

Another sensitivity case is the use of static cables between floaters. In the following case it has been assumed that 20% of farms using static cable in 2031-2040, 30% in 2041-2050. The static cable sections span the longitudinal distance between turbines, and the approximate distance from OSS to the first turbine in a string. The remaining cables are dynamic as in the baseline study. The revised wind farm deployment scenario is shown in Appendix 2 (Table 20).

Table 18 shows updated projected requirements for static and dynamic cables. The numbers of ancillary components such as buoyancy modules, interface connections and cable protection are not shown as these would not be anticipated to change.

Item	unit	2021-2030	2031-2040	2041-2050	Total
Dynamic cables (copper)	km	367	2,336	3,652	6,355
33 kV (wet) cable		92	169	0	261
240 mm ²		55	79	0	134
630 mm ²		37	90	0	127
66 kV (wet) cable		275	1,940	2,948	5,163
240 mm ²		165	956	1,488	2,609
630 mm ²		110	368	0	478
800 mm ²		0	615	1,460	2,076
132 kV (dry) cable		0	227	704	931
240 mm ²		0	179	554	733
630 mm ²		0	48	150	198
Static cables (copper)	km	0	328	1,125	1,453
33 kV (wet) cable		0	0	0	0
240 mm ²		0	0	0	0
630 mm ²		0	0	0	0
66 kV (wet) cable		0	328	938	1,266
240 mm ²		0	179	525	704
630 mm ²		0	39	0	39
800 mm ²		0	110	413	523
132 kV (dry) cable		0	0	188	188
240 mm ²		0	0	150	150
630 mm ²		0	0	38	38

Table 18: Cable Requirements – Use of Static Cables Sensitivity Analysis

5.4 INTRODUCTION OF TLPs

The introduction of TLP floater designs in the future as sites move into deeper waters may also impact on the component requirements. It is possible that due to reduced floater motions with TLPs that catenary cable configurations may be feasible, rather than the lazy wave presented in this work.

Should catenary cable configurations be utilised then the requirement for buoyancy modules to create the lazy wave shape would be eliminated for these systems. They may also require slightly shorter dynamic cable lengths (e.g. approx. 1.3 times water depth in the dynamic portion, rather than 2 times water depth in the case of the lazy wave).

Uptake of TLPs may be in the region of 10%, from 2030 onwards.

5.5 FLOATING OFFSHORE SUBSTATIONS

In future, as sites move to deeper waters, it is likely that floating offshore substations may be adopted when they become financially attractive in comparison to deep water jacket foundations. This is also dependent on high voltage dynamic export cable technology being ready.

If floating offshore substations are adopted then the required components will include additional dynamic components such as I-tubes, dynamic hang-off assemblies and bend stiffeners, along with a reduction or elimination of static components such as J-tubes, static hang-off assemblies and bend restrictors.

Some additional cable length will also be required to account for the lazy wave configuration at the offshore substation.

5.6 WIND FARM LAYOUT AND SUBSTATION SIZE

For simplicity, this study has considered a single FOW project size of approximately 500 MW, assuming that larger farms will be built in stages. Some project phases will likely be larger than this, and AC substation capacity is anticipated to reach 750 MW by around 2030 – 2035. This would alter the wind farm layout and number of strings, potentially altering the cable sizes and lengths required.

Additionally, this work has covered just one string arrangement, and alternative arrangements including radial loops are possible, some requiring additional (or less) cable length.

6 GLOBAL MARKET REQUIREMENTS

The values presented in Section 4 and Section 5 are for the predicted UK deployment only. Referring back to the projections in Section 2.2, globally 204 GW of FOW is anticipated by 2050. This includes 49 GW in the UK (baseline assumption).

Specific global projections have not been developed, as the anticipated floater types, water depth and metocean conditions vary significantly worldwide, and so the lazy wave configuration assumed suitable for the UK may not be applicable overseas. However, based on the deployment numbers, the total global size of the market and demand for cable products and services is likely to be around four times those presented in this report.

7 SUMMARY

This report has presented a view on the required dynamic cable components for UK FOW projects given three different UK offshore wind deployment scenarios:

- 75 GW offshore wind by 2050 (29 GW FOW)
- 100 GW offshore wind by 2050 (49 GW FOW) – base case
- 150 GW offshore wind by 2050 (95 GW FOW)

The predicted component requirements are shared to inform the supply chain of the upcoming scale of work in this area. The figures presented should be used as an indication only – they are based on a number of assumptions which are stated throughout the report, but will depend on how the market develops and how specific cable systems are defined.

It is clear however that the opportunity in this area is large, and increases further when considering the global market. Around 8,000 km of dynamic cables are estimated to be needed in the baseline scenario (around 2,500 lengths), along with 5,000 cable protection tubes, terminations and hang-off assemblies, and in the region of 80,000 buoyancy modules. The associated services required are also extensive, and the UK supply chain has good relevant experience from both bottom-fixed win and from oil and gas projects.

APPENDIX 1 CABLE MATERIAL ALTERNATIVE DEPLOYMENT SCENARIO

# Farms	Turbine Size	Voltage	Depth	Material	
2021-2030 (1,980 MW, 4 farms)					
1	15 MW	33 kV	mid	copper	
2		66 kV	mid	copper	
1			mid	aluminium	
2031-2040 (16,540 MW, 33 farms)					
2	18 MW	33 kV	mid	copper	
2			66 kV		shallow
2					mid
1		deep			
1		shallow		aluminium	
2		mid			
1		deep			
2	20 MW	66 kV	shallow	copper	
7			mid		
2			deep		
2			shallow		
4			mid		
2			deep		
1			132 kV		mid
1		deep			
1		mid		aluminium	
2041-2050 (30,500 MW, 61 farms)					
10	20 MW	66 kV	shallow	copper	
9			mid		
10			deep		
7			shallow		aluminium
6			mid		
7			deep		
3		132 kV	shallow	copper	
2			mid		
3			deep		
1			shallow		aluminium
2			mid		
1		deep			

Table 19: Wind Farm Deployment Scenario – Cable Material Sensitivity Analysis

APPENDIX 2 STATIC CABLE ALTERNATIVE DEPLOYMENT SCENARIO

# Farms	Turbine Size	Voltage	Depth	Use of static?	
2021-2030 (1,980 MW, 4 farms)					
1	15 MW	33 kV	mid	N	
3		66 kV	mid	N	
2031-2040 (16,540 MW, 33 farms)					
2	18 MW	66 kV	33 kV	mid	N
2			shallow	N	
3			mid		
2			deep		
1			shallow		Y
1			mid		
3	20 MW	66 kV	shallow	N	
9			mid		
3			deep		
1			shallow	Y	
2			mid		
1			deep		
2		132 kV	mid	N	
1			deep		
2041-2050 (30,500 MW, 61 farms)					
12	20 MW	66 kV	shallow	N	
9			mid		
13			deep		
5			shallow	Y	
5			mid		
5			deep		
3		132 kV	shallow	N	
3			mid		
3			deep		
1			shallow	Y	
1			mid		
1			deep		

Table 20: Wind Farm Deployment Scenario – Static Cable Sensitivity Analysis

FLOATING OFFSHORE WIND
CENTRE OF EXCELLENCE

Delivered by
CATAPULT
Offshore Renewable Energy

CONTACT US

ore.catapult.org.uk
info@ore.catapult.org.uk

ENGAGE WITH US



GLASGOW

Inovo
121 George Street
Glasgow
G1 1RD
T +44 (0)333 004 1400

BLYTH

National Renewable Energy
Centre Offshore House
Albert Street
Blyth, Northumberland
NE24 1LZ
T +44 (0)1670 359 555

LEVENMOUTH

Fife Renewables Innovation
Centre (FRIC)
Ajax Way
Leven
KY8 3RS
T +44 (0)1670 359 555

HULL

O&M Centre of Excellence
Ergo Centre
Bridgehead Business Park
Meadow Road, Hessle
HU13 0GD

ABERDEEN

Subsea UK
30 Abercrombie Court
Prospect Road, Westhill
Aberdeenshire
AB32 6FE

CORNWALL

Hayle Marine Renewables
Business Park
North Quay
Hayle, Cornwall
TR27 4DD

PEMBROKESHIRE

MEECE
Pembroke Dock
Pembrokeshire
South West Wales

CHINA

11th Floor, Lan Se Zhi Gu No.5
Ke Ji Avenue, Hit-Tech Zone
Yantai City
Shandong Province
China